

# HIGH CAPACITY MANURE GRAB

AGRICULTURAL HANDLING Solutions



## ADVANTAGES

- Massive and efficient attachment.
- Excellent visibility thanks to innovative design.
- The best solution for manure handling.
- Improved design allows working flush with walls.
- Versatile attachment that enables occasional square bale handling.

## TECHNICAL CHARACTERISTICS

- Large capacity 2000 L.
- Grapple "open/close" stop plates ensure long life for hydraulic cylinders.
- Bolt-on teeth and tines for easy maintenance.
- High quality wear resistant and high yield steels used extensively.
- Teeth: Ø 45 mm, 939 mm.
- Tines: Ø 45 mm, 1100 mm.

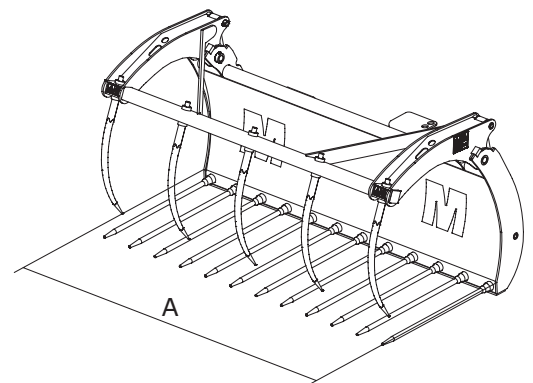
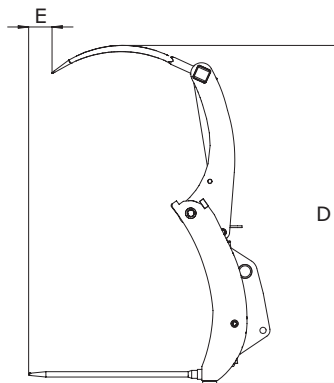
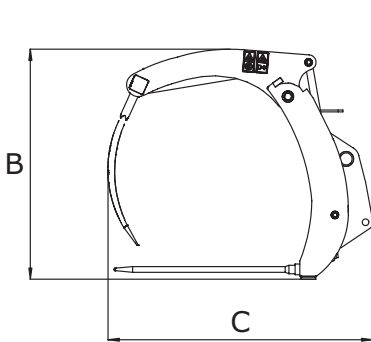

	Capacity (L)	A (mm)	B (mm)	C (mm)	D (mm)	E (mm)	Teeth	Tines	Weight (kg)
<b>FMG 2100/1800</b>	1800	2095	1223	1352	-	-	4	10	470
<b>FMG 2450/2000</b>	2000	2435	1225	1411	1932	134	5	12	686

## COMPATIBILITY\*

	FMG 2100/1800	FMG 2450/2000
<b>Part Number</b>	52000082	790534
<b>MLT 629</b>	X	
<b>MLT 634</b>		X
<b>MLT 735</b>		X
<b>MLT 741</b>		X
<b>MLT 840</b>		X
<b>MLT 1040</b>		X

\* This Attachment has been approved for the machines listed above.  
A load chart Machine/Attachment has been created accordingly.



This brochure describes versions and configuration options for Manitou products which may be fitted with different equipment. The equipment described in this brochure may be standard, optional or not available depending on version. Manitou reserves the right to change the specifications shown and described at any time and without prior warning. The manufacturer is not liable for the specifications given. For more information, contact your Manitou dealer. Non-contractual document. Product descriptions may differ from actual products. List of specifications is not comprehensive. The logos and visual identity of the company are the property of Manitou and may not be used without authorisation. All rights reserved. The photos and diagrams contained in this brochure are provided for information only. MANITOU BF SA - Limited company with board of directors - Share capital: 39,547,824 euros - 857 802 508 RCS Nantes FMG\_EN\_E\_0215



www.manitou.com